

PCB MOUNTING HOLES(±0.1)
(COMPONENT SIDE)

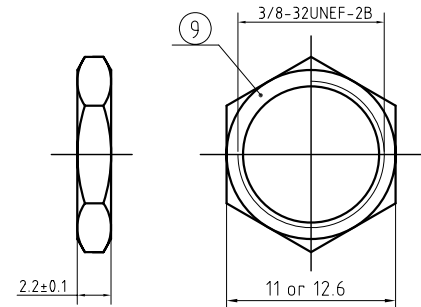
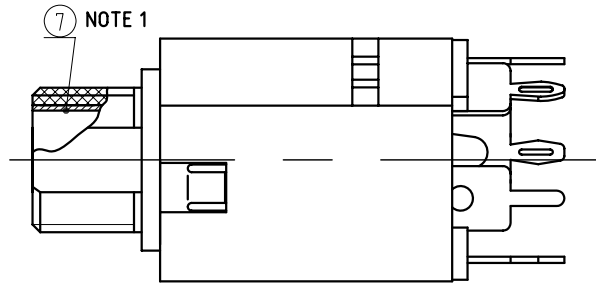

HEX NUT

FLAT WASHER

PART No.	ACJM-MIV-2	ACJM-MIV-2S	ACJS-MIV-3	ACJS-MIV-3S	ACJS-MIV-5
SCHEMATIC					

9	HEX NUT	1	H59 (COPPER ALLOY)	Ni-PLATED(Cu:2-3um, Ni:2-3um) RoHS COMPLIANT
8	FLAT WASHER	1	H62Y OR STEEL t=0.5	
7	METAL TUBE	1	H59 (COPPER ALLOY)	Ag-PLATED(Cu:2-3um, Ag:0.3um) RoHS COMPLIANT
6	BODY	1	PBT G10 94HB	
5	5# TERMINAL	1	H62Y t=0.4 (C2680R-H)	
4	4# TERMINAL	1	H62Y t=0.4 (C2680R-H)	
3	3# TERMINAL	1	QSn6.5-0.1Y t=0.35 (C5210R-H)	
2	2# TERMINAL	1	QSn6.5-0.1Y t=0.4 (C5210R-H)	
1	1# TERMINAL	1	QSn6.5-0.1Y t=0.4 (C5210R-H)	
NO.	NAME	QTY	MATERIAL(THICK,COLOR)	REMARK

NOTE 1: METAL TUBE IS NOT CONNECTED TO TERMINAL 1

UNLESS OTHERWISE SPECIFIED TOLERANCE TO BE		THIS DOCUMENT IS THE PROPERTY OF AMPHENOL AUSTRALIA PTY. LTD.. NO PART THEREOF MAY BE REPRODUCED AND USED WITHOUT THE PRIOR WRITTEN CONSENT OF THE OWNER				0	FIRST ISSUE	M.H	19-11-09	----
LINEAR	ANGULAR	REV.	CHANGE DETAILS	BY	DATE	CHG/No				
X ± 0.5	X° ± 1°	CAD FILE:	55010639000110	DRN:	M.H	DATE:	19-11-09	TITLE:		
X.X ± 0.1	X°X' ± 30'	MATL:	SEE TABLE	CKD:	M.H.	DATE:	19-11-09	6.5mm INSULATED VERTICAL JACK CUSTOMER DRAWING		
X.XX ± 0.05	X°X'X" ± 15"	DO NOT SCALE	FINISH:	APP'D:	M.H.	DATE:	19-11-09	DRAWING NO. 55010639-000-1		
BREAK ALL SHARP EDGES AND REMOVE ALL BURRS		SCALE:		NTS	PART No:		SEE TABLE	SIZE:	A4	SHEET 1 OF 1

1

2

3

4

5

6